

ITO-220AC

FEATURES:

- Plastic package has Underwriters Laboratory Flammability Classification 94V-0
- Ideally suited for freewheeling diode power factor correction applications
- Excellent high temperature switching
- Optimized to reduce switching losses
- High temperature soldering guaranteed : 250°C /10 second,0.25"(6.35mm)from case

MECHANICAL DATA

Case : JEDEC ITO-220AC molded plastic
 Terminals : Leads solderable per MIL-STD-750 Method 2026
 Position : As marked
 Mounting Position : Any
 Mounting Torque : 5 in - lbs.max
 Weight : 0.08 ounce,2.24grams

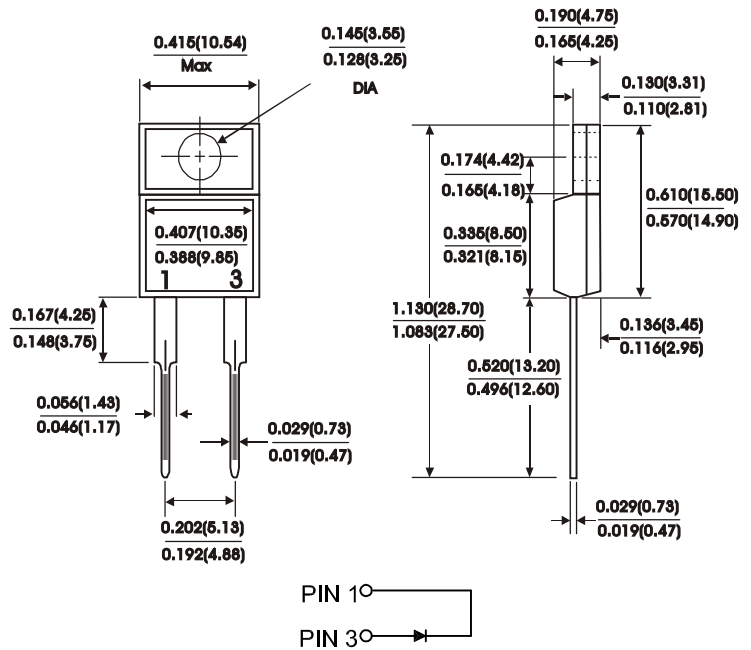

Dimensions in inches and (millimeters)

MAXIMUM RATINGS AND ELECTRICAL CHARACTERISTICS

Rating at 25 °C ambient temperature unless otherwise specified.

Single phase half wave, 60 Hz resistive or inductive load.

For capacitive load, derate current by 20%.

Characteristic	Symbol	SFF 10005	SFF 1001	SFF 1002	SFF 1003	SFF 1004	SFF 1006	Units
Maximum recurrent peak reverse voltage	V_{RRM}	50	100	200	300	400	600	Volts
Maximum RMS voltage	V_{RMS}	35	70	140	210	280	420	Volts
Maximum DC blocking voltage	V_{DC}	50	100	200	300	400	600	Volts
Maximum average forward rectified current at $T_c=100^\circ\text{C}$	$I_{(AV)}$	10.0						Amps
Peak forward surge current 8.3ms single half sine-wave superimposed on rated load (JEDEC Method)(Per leg)	I_{FSM}	100						Amps
Maximum instantaneous forward voltage (Per leg) $I_F=10.0\text{A}$	V_F	1.0		1.30		1.70		Volts
Maximum DC reverse current at rated DC blocking voltage (Per leg) $T_c=25^\circ\text{C}$ $T_c=125^\circ\text{C}$	I_R	10.0 500.0						μA
Typical reverse recovery time(NOTE 1)(Per leg)	T_{RR}	35						nS
Typical junction capacitance (NOTE 2)(Per leg)	C_J	65						P_F
Operating temperature range	T_J	-55to+150						$^\circ\text{C}$
Storage temperature range	T_{Stg}	-55to+150						$^\circ\text{C}$

NOTES:

(1)Reverse Recovery Test CONDITION : $I_F=0.5\text{A}$, $I_R=1.0\text{A}$, $I_{RR}=0.25\text{A}$

(2)Measured at 1MHZ and reverse Voltage of 4.0V

FIG.1 - TYPICAL FORWARD CORRENT DERATING CURVE

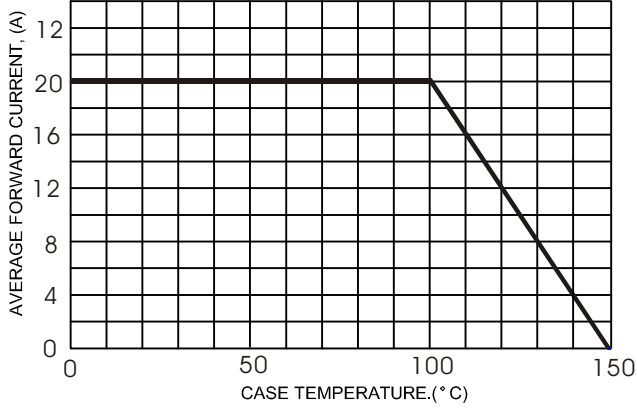

FIG.2 - TYPICAL FORWARD CHARACTERISTICS

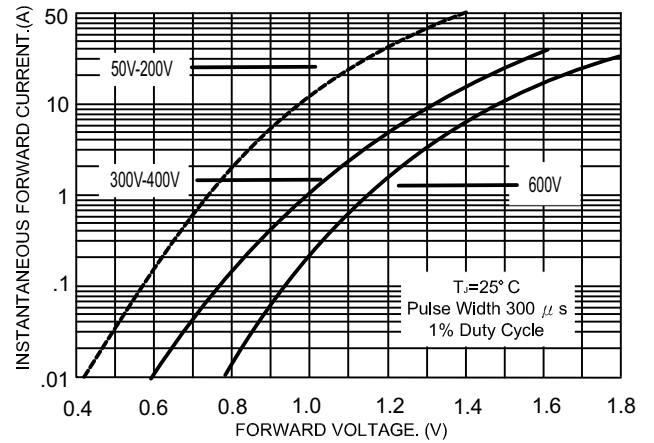

FIG.3 - MAXIMUM NON-REPETITIVE FORWARD SURGE CURRENT

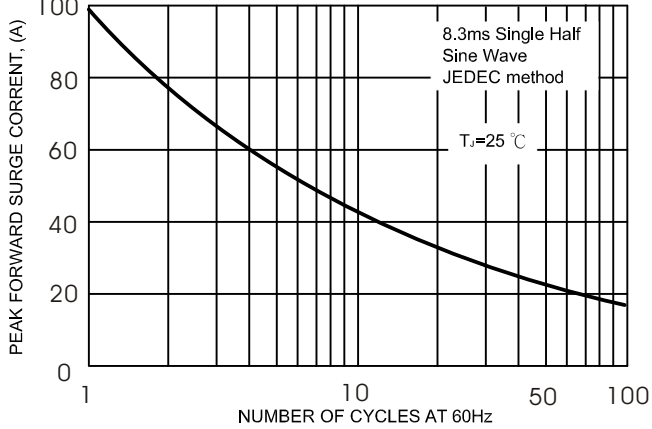

Figure 6 GR1 Test Circuit

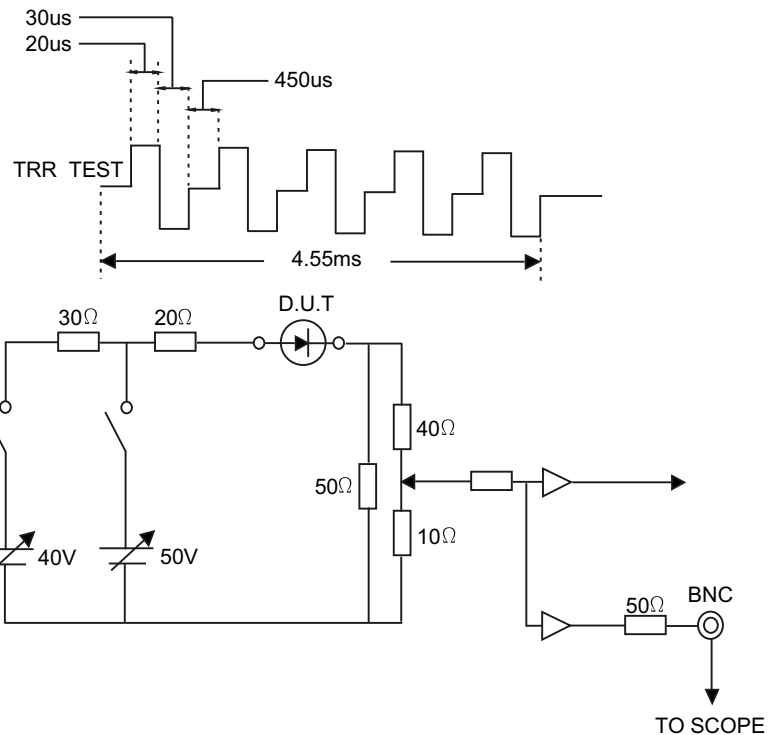

FIG.4- TYPICAL JUNCTION CAPACITANCE

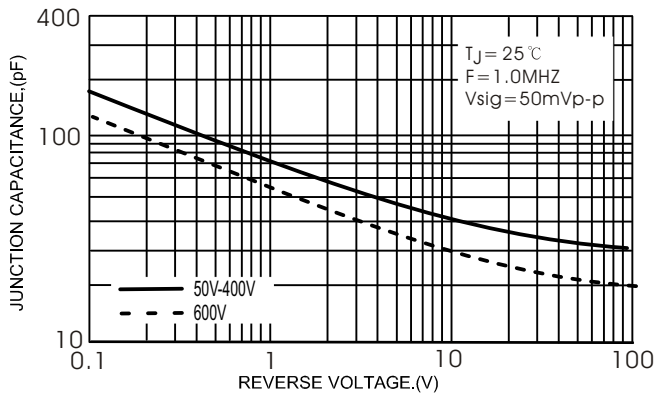

FIG.5- TYPICAL REVERSE CHARACTERISTICS

